

## 【縁塊 (800~1000用)】

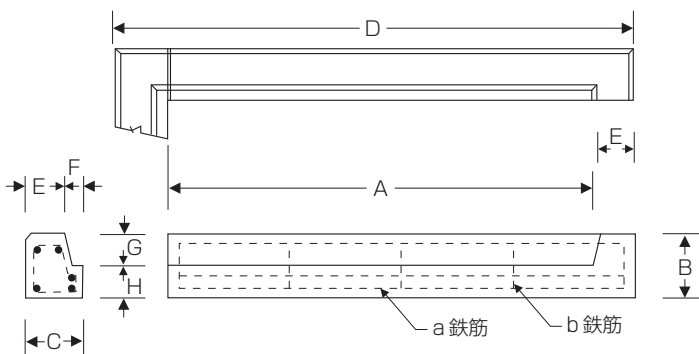

## 縁塊 (750用)

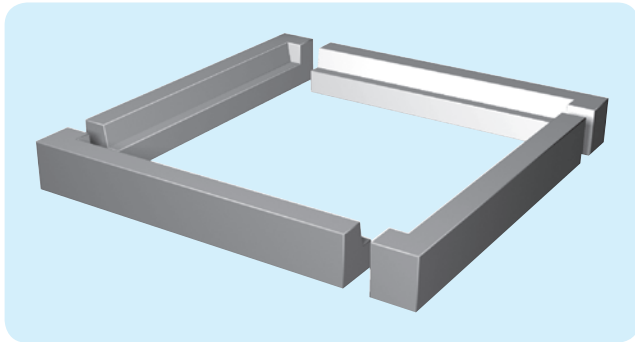
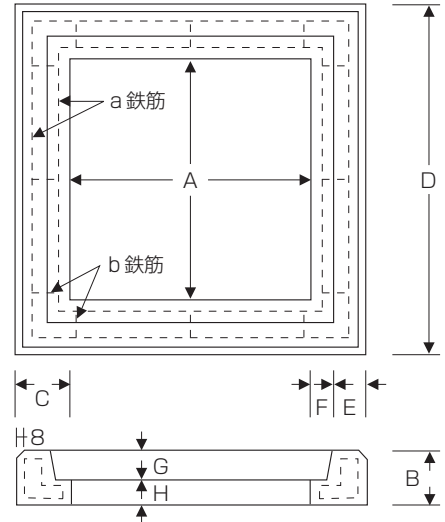

## 【蓋】

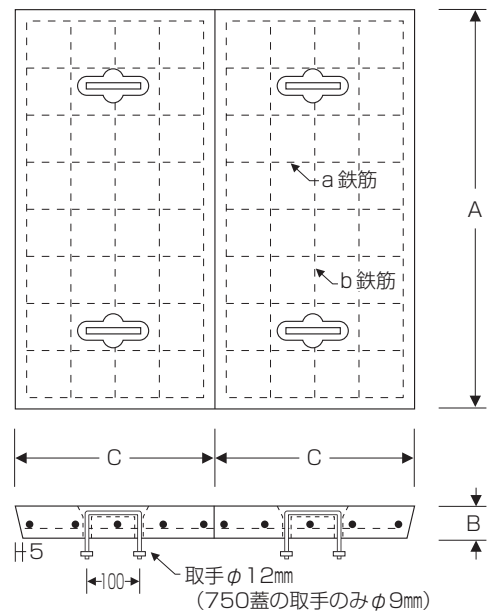
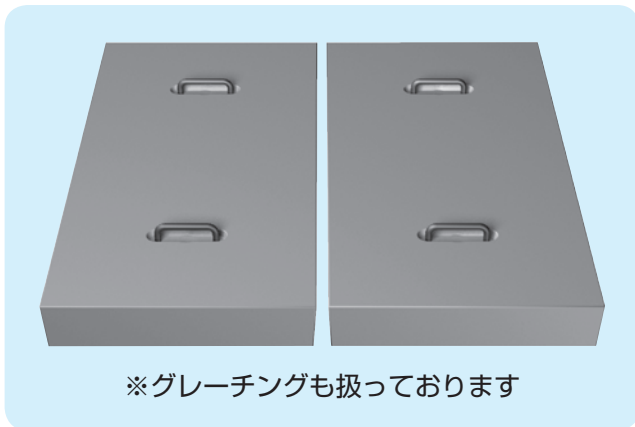

### ■仕様寸法表 (単位mm)

名称	A	B	C	D	E	F	G	H	a 鉄筋	b 鉄筋	重量	
縁塊	750	750	130	115	980	80	35	60	70	径6mm 5本	径4mm 12本	106kg
	800	800	130	110	1015	80	30	60	70	径6mm 5本×4	径4mm 5本×4	112kg
	900	900	130	110	1115	80	30	60	70	径6mm 5本×4	径4mm 5本×4	124kg
	1000	1000	130	110	1215	80	30	60	70	径6mm 5本×4	径4mm 6本×4	136kg
蓋	750	814	60	407	—	—	—	—	—	D-10 9本×2	D-10 5本×2	94kg
	800	864	60	432	—	—	—	—	—	D-10 9本×2	D-10 5本×2	108kg
	900	964	60	482	—	—	—	—	—	D-10 9本×2	D-10 5本×2	134kg
	1000	1064	60	532	—	—	—	—	—	D-10 10本×2	D-10 5本×2	162kg

